

>> **HN-9UM** rangehood/**UNDERMOUNT**/90cm

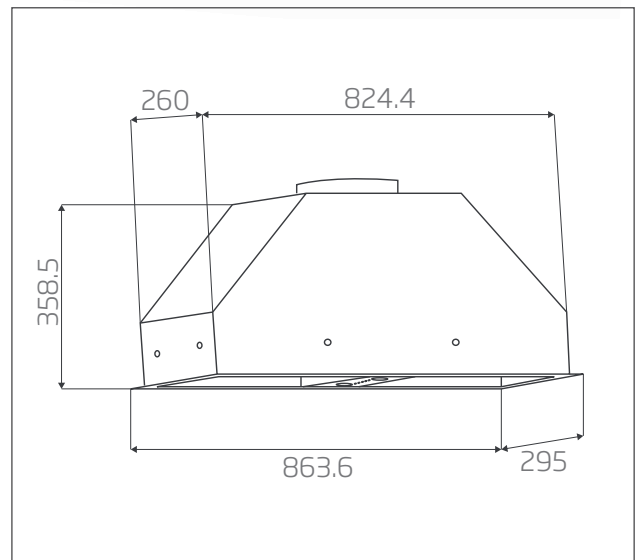

- **simple design** - stainless steel undermount rangehood integrates seamlessly with kitchen cabinetry, create functional, integrated kitchen style.
- **powerful extraction** - 1080m³/h efficient extraction of steam, smoke and odours, leaves kitchen air fresher.
- **3 Year Warranty** - peace-of-mind with product guarantee
- **recirculating** carbon filter available*



*Optional accessories and parts can be ordered via our local customer service department on **1300 829 066**



Description	Technical data
<ul style="list-style-type: none"> • stainless steel finish • 3 x speed levels • 2 x LED lights • dishwasher safe metal filters • 3 Year Warranty on rangehood • recirculating carbon filter available* 	<p>HN-9UM</p> <ul style="list-style-type: none"> • Airflow rate: 1080m³/h • dimensions: (W x D) 863.6 x 295 mm • 2 x mesh filters • Noise level: 52.2 dB on the lowest setting